

D6XX

DUAL PURPOSE DRYER

PRODUCT SPECS

Machine Dimensions

Width (in) (Shipping)	46-5/8" (62")
Depth (in) (Shipping)	54-1/4" (62")
Height (in) (Shipping) 1	80-1/4" (91")
Clearance (Rear/Sides)	1" / 10" min.

Machine Weight

Crated Weight (lb)	1240
--------------------	------

Available Electrical

D612 - 2 WIRE	240V/1PH/60HZ - 30.1 A
D613 - 3 WIRE	208V/1PH/60HZ - 27.5 A
D633 - 3 WIRE	240V/3PH/60HZ - 19.6 A
D634 - 4 WIRE	208V/3PH/60HZ - 17.7 A

Recommended Fuse

D612/D613/D633	35 A
D634	30 A

Performance

AirFlow (cfm)	900
Heating (W)	1000

Included Equipment

Shelves	10
Glove Hangers	6
Gear Hangers	6

Warranty (yrs)

10

Note 1: w/o ducting

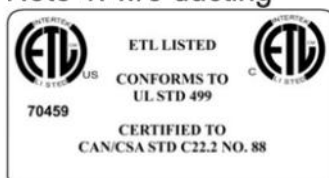

NFPA 1851 COMPLIANT



DIMENSIONAL DRAWING FOR



DRYING CABINET

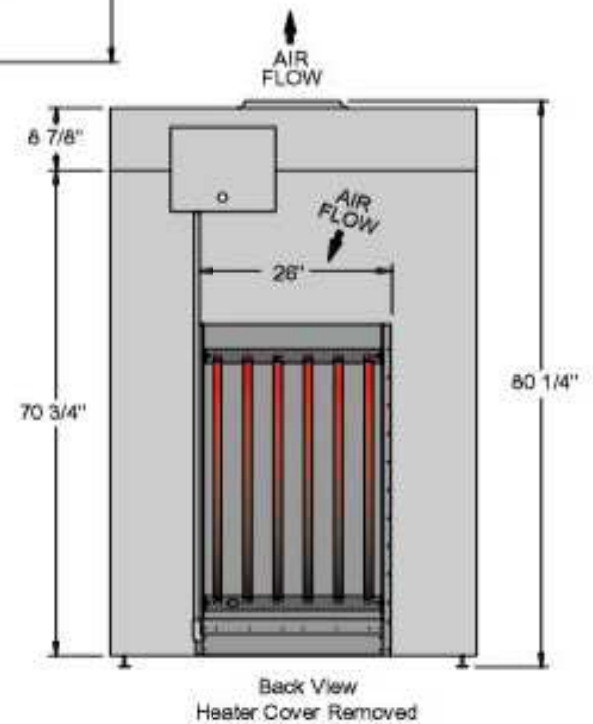
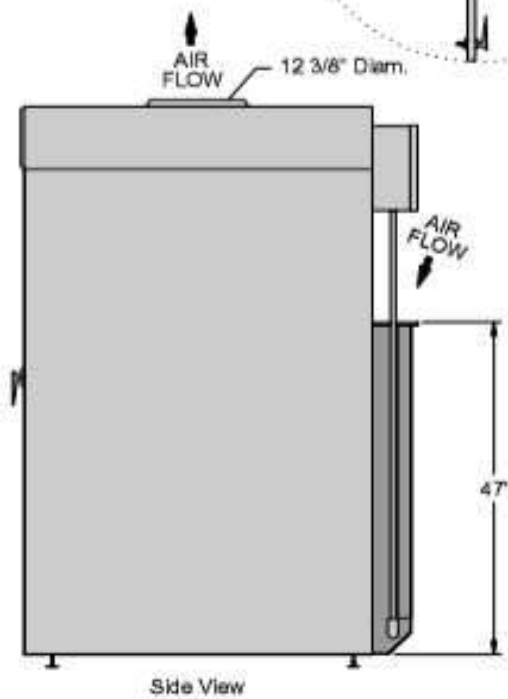
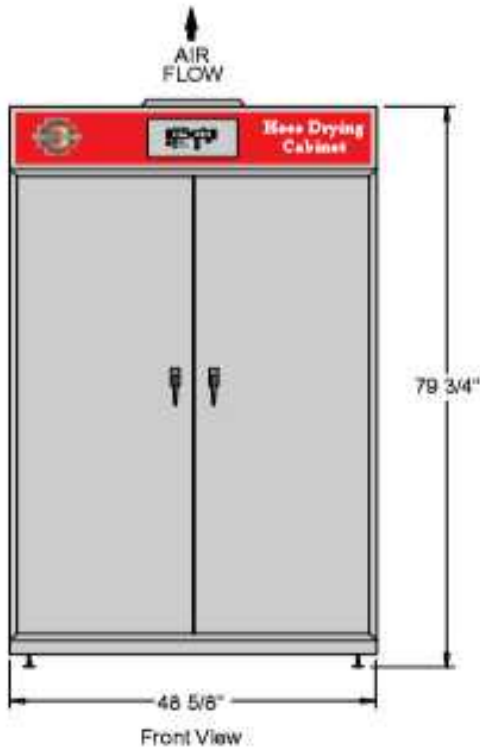
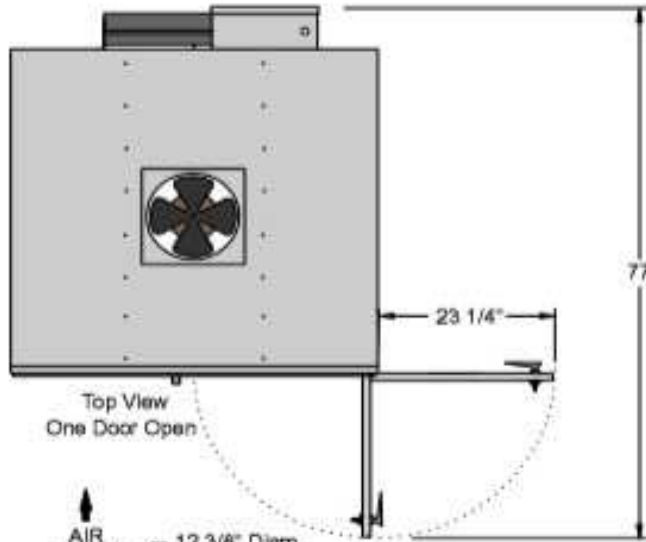
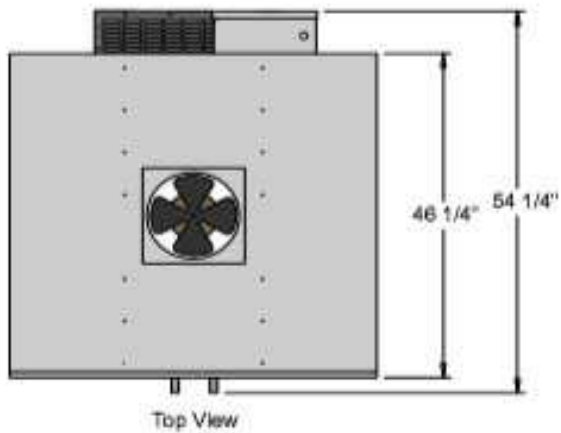

REVISION	08-12-2014
----------	------------

Drawing Number	??
Drawn By:	Troy J.
Date:	03-31-03